

Figure number  
**2.3584**

## FLAT BODY FABRICATED STEEL GATE VALVES

DOUBLE FLANGED PN 10, BOLTED BONNET, RISING STEM,  
DOUBLE DISC, STAINLESS STEEL TRIM

**PN 2.5**

**300 °C**

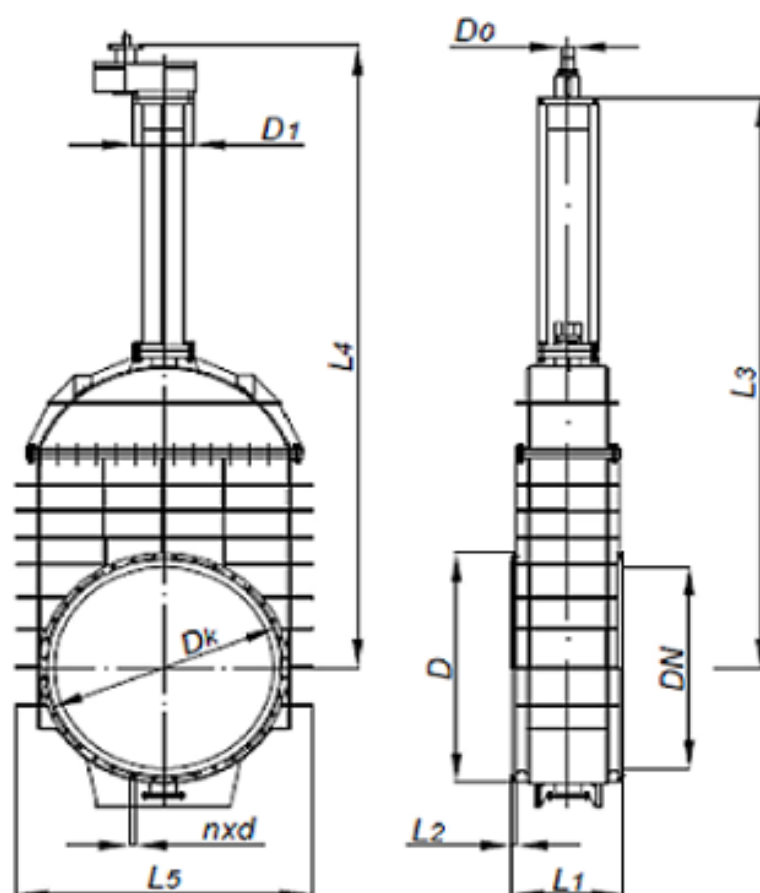

### STANDARD VALVE MATERIALS

Part name	Material type	Mater. No.
Body, bonnet	Unalloyed steel	1.0038
Gasket	Graphite	-
Stud bolts	Bolting steel	1.7218
Nuts	Bolting steel	1.1191
Stem	Stainless steel	1.4021
Packing	Graphite	-
Wedge	Unalloyed steel	1.0038
Body seats	13Cr-Mo hardfacing	1.4115
Wedge seats	13Cr-hardfacing	1.4015

DN	PN	D	Dk	Do	D1	d	n	L1	L2	L3	L4
800	2.5	1015	950	50	300	33	24	470	32	2515	3035
1000	2.5	1230	1160	60	300	36	28	550	34	3140	3660
1200	2.5	1455	1330	65	350	39	32	630	38	3770	4020
1400	2.5	1675	1590	80	410	42	36	710	42	4260	4500
1500	2.5	1690	1630	85	410	42	36	750	42	4750	5000

Nominal size DN	Pressure rating PN	Allowable working pressure [bar] at working temperature			For neutral liquid, gases and vapours, steam and condensate	Test pressures [bar]	
		100 °C	200 °C	300 °C		Shell & obturator P10,11,20	Seat & backseat P12,21
800-1500	2.5	2.2	1.8	1.4	Environment temper. up to -10°C	3.75	2.75